

Body Graphics — Side Stripes

Special Tool(s)

 <p>ST1073-A</p>	<p>Heat Gun 107-R0300</p>
---	-------------------------------

Body Side Stripe Decal — All Vehicles

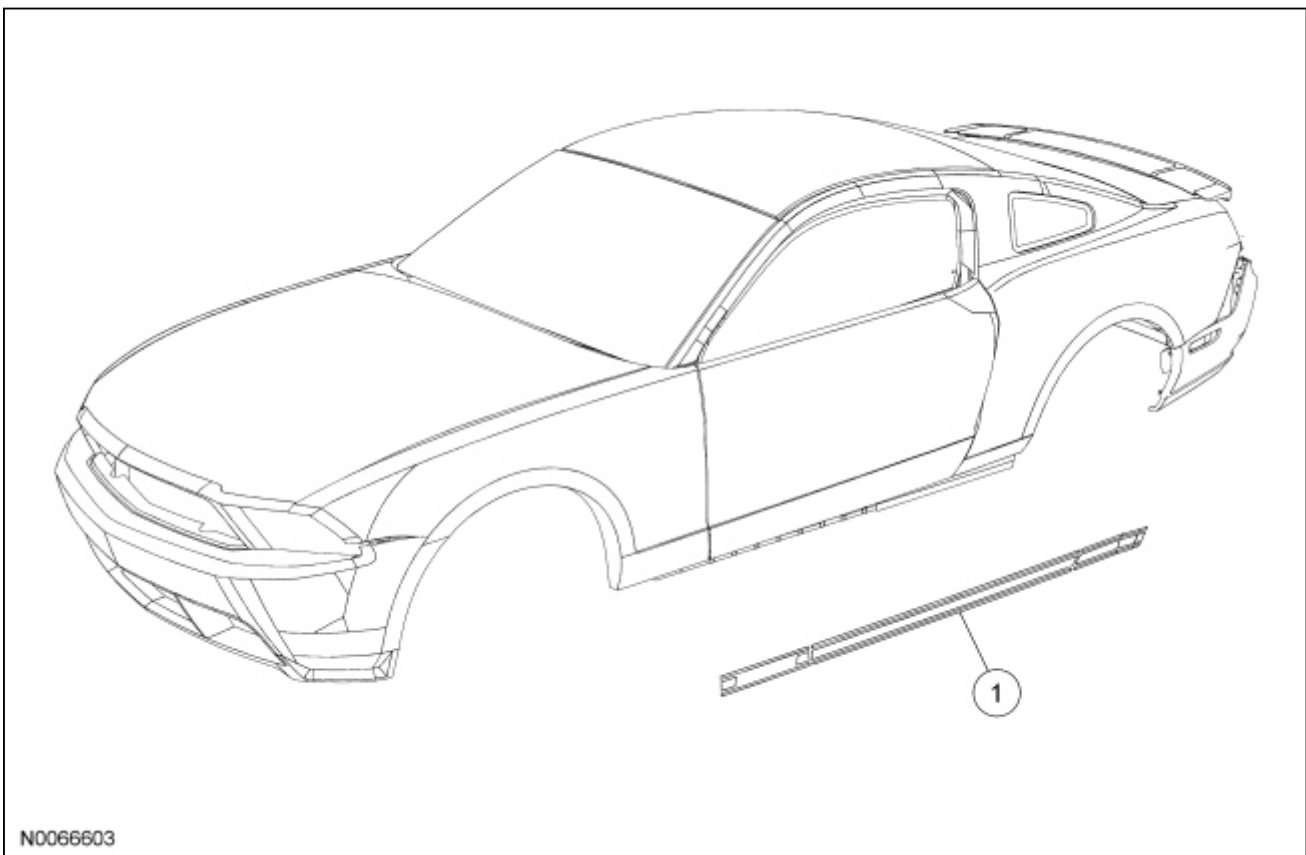

Item	Part Number	Description
1	20000AB LH/ 20000AA RH	Body side stripe decal

NOTE: Surface temperature of body panel(s) should be above 10°C (50°F). Avoid carrying out removal or installation of stripe decal(s) in direct sunlight.

1. Thoroughly wash and dry the vehicle before carrying out removal and installation of stripe decals.
2. Warm the stripe decal on the affected panel with a hair dryer or heat gun on the lowest setting, being careful not to heat excessively, as this can melt the decal or damage the paint surface.
 - Beginning at the edge or corner of the stripe, slowly lift and remove the stripe, pull at an angle to the body panel. Keep the stripe warm with a heat gun or hair dryer slightly ahead of the area just removed.
 - Remove any remaining material or adhesive from the panel surface with an isopropanol cleaner or equivalent.

- An alternate method of removing stripes is with a rubber-wheeled graphic removal tool.

Installation

1. Clean the surface using a commercially available wax and grease remover, follow manufacturer's directions.
2. Reclean the surface using an isopropanol cleaner.
3. Mix 1 teaspoon of liquid dishwashing soap or equivalent in 1.89L (1/2 gal) of water. Fill a spray bottle with the solution.
4. **NOTE:** Dry fit and masking tape the stripe in position or, use an assistant to locate and position the new stripe decal.

Position side stripe so the locator notches align with the fender-to-door gap.

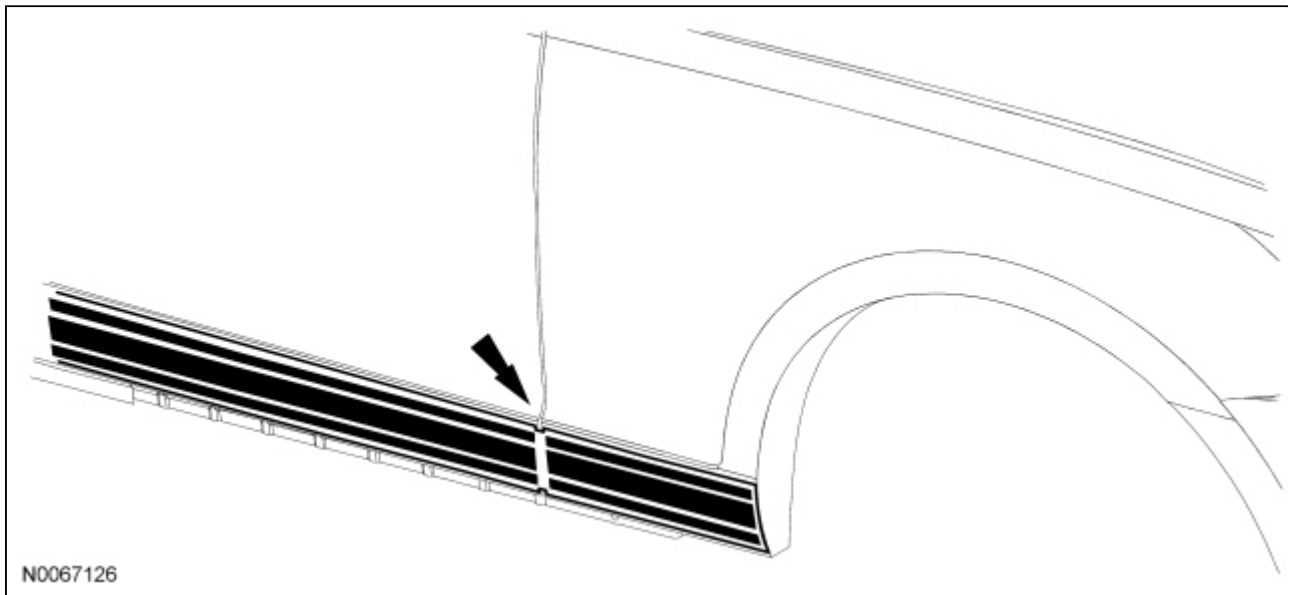

5. Check positioning of locator notches at the door-to-quarter panel gap.

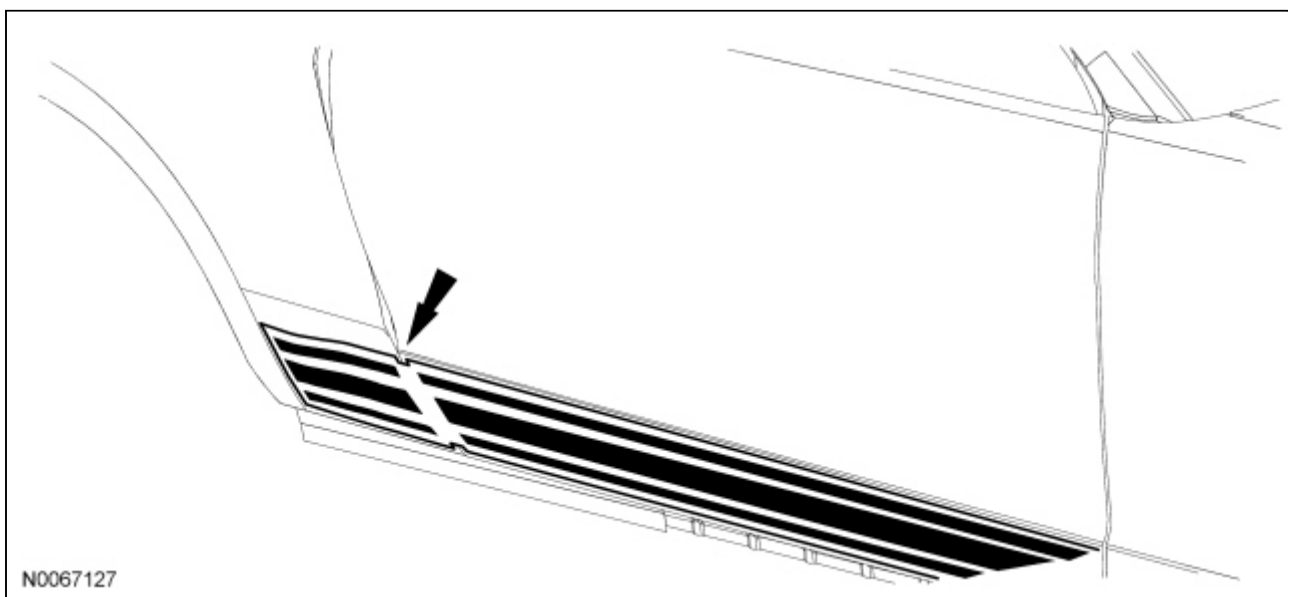

6. Partially remove the body side stripe decal(s) adhesive liner paper as necessary.
 - Remove a small section of the liner from the adhesive side of the new stripe decal and wet with the water/soap solution.

- Position and apply the new decal, removing the adhesive liner while pressing the decal into position, spraying the adhesive surface with the soap/water solution. Work from the front to the rear of the decal, while maintaining correct position of the decal on the vehicle.
 - Use a plastic squeegee and work diagonally along the stripe decal to remove the excess air and water/soap solution until the decal is firmly adhered. Wet the release paper with the water/soap solution and slowly remove the release paper, pulling at 180 degrees and a diagonal to the stripe decal.
7. Repair blisters or air bubbles by piercing them with a small pin or needle at one end of the bubble. Work the trapped air out through the pin hole using a soft plastic squeegee, thumb or finger, moving toward the pin hole and press the stripe firmly against the panel. It may be necessary to preheat the panel slightly to soften the adhesive. Heat may also be used to remove small creases or irregularities.
-